

Current Transformer Model EI-7SP-1600-00

Window Size 2.88" x 6.25"



Catalog Number	Current Ratio	Accuracy @ 60 Hz *		Nominal Winding Resistance (ohm)	Lead Wire Size (AWG)
		±%	Burden (VA)		
EI-7SP-1600-00	1600:5A	1.0	25	0.54	16

Specifications

- Secondary sources 5 A AC at rated F.S. primary current.
- Nominal operating frequency range is (50 - 400) Hz.
- Thermal rating factor is 1.33 @ 30 °C for all ratios.
- Insulation voltage class is 0.6 kV BIL 10 kV.
- For indoor applications only.
- Lead wire length is 36 inches.
- CT can be split apart and reassembled onto the primary conductor without interrupting service.

NOTE: Safety precautions must be observed.

- CT is finished in heavy vinyl tape with dipped acrylic overcoat; uses embedded SS band to secure two halves of transformer together.

Notes for diagram on the right:

1. Dimensions are in inches.
2. All dimensions are for reference only.
3. All dimensions are measured over the highest point of the appropriate surface.
4. White lead wire is electrically in phase with "HI" side of transformer (with polarity marks).

CAUTION! Potentially lethal voltages may appear on terminals if the terminals are not electrically connected together when installing onto an energized system. It is imperative that leads and/or terminals be shorted together or attached to the intended burden prior to such installation.

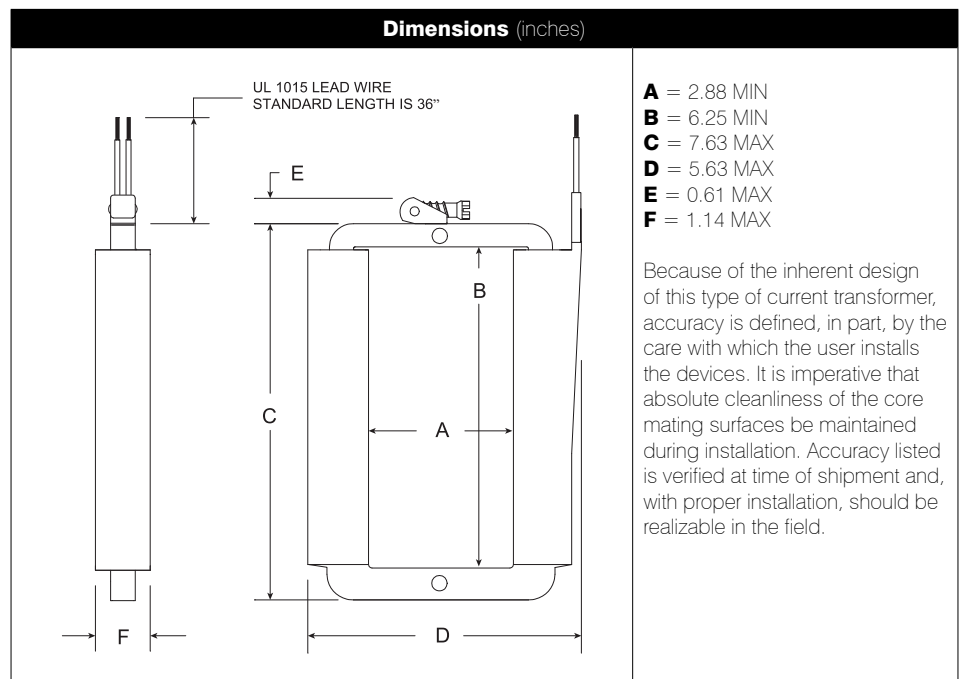

1800 Shames Drive
Westbury, NY, 11590

1-877-EIMETER
(1-877-346-3837)

Tel: 516-334-0870
Fax: 516-338-4741

Email: EIG_sales@hubbell.com
Website: www.electroind.com

